

Emergency Response Plan SMART App



INTRODUCTION

After an emergency, when you need to react quickly and decisively, your emergency response plan will likely become the single most important asset in your organization. You will need to access it quickly, make it available to your first responders and hope that it is current and relevant. SMART Response takes your emergency response plan off the shelf and puts it in the hands of those that need it most.

Varius specializes in Risk and Resiliency Assessments for water and sewer systems and in Emergency Response Plans for water and sewer systems. In conjunction with our Response Plan work, Varius has developed a new and innovative tool to improve the efficiency and effectiveness of your response planning efforts.

An Emergency Response Plan is uniquely valuable after an emergency. When your staff is compromised or unavailable, your resources are limited, and your normal operations and processes have stopped, the ability to access your data, communicate with your staff, and complete well thought-out actions is critical. During an emergency, however, will you know where your plan is? Or be able to access it? Will it be current? Will it be organized in a way that complements that particular emergency? Unfortunately, the answer to many of these questions is usually “no”.

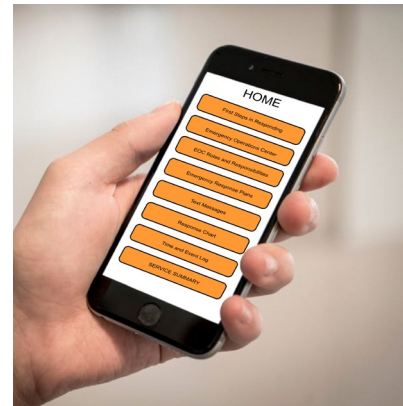

INTRODUCING SMART RESPONSE

Varius has developed an APP, available for your Android and iOS smart phone, iPad or other mobile device, that contains an organized, easy to access and easy to use version of your Emergency Response Plan. For the first time, your plan will be available when you need it, where you need it, and it will be current. In addition, we can link your SMART plan to your SCADA system so that all of your operational data is not only accessible at your fingertips, but you can control your facilities right from your phone. Imagine having the following capabilities:

- Your staff can be tracked. You will know where they are and what they are doing during and after an emergency,
- Your staff can check in using their own version of the SMART App. They can ask for help, send you status updates, and let you know if they are or aren't available to assist,
- You can communicate with your entire staff using a completely independent communication system. When the radios and phones are down, the SMART App will still be able to communicate with the other SMART devices,



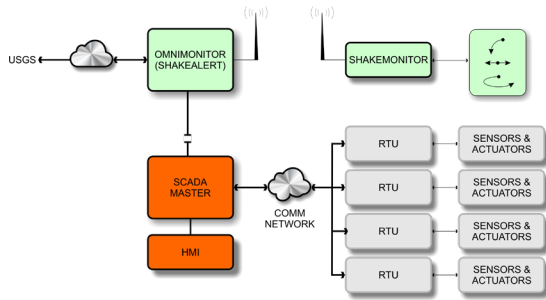

- You can track their actions and organize their facility responses right from your mobile device. These are logged and archived so you have a record of what was done, and when,
- You can get automatic updates about the condition of your facilities, what is operating normally and what is broken,
- You can update your phone trees, your org charts, your personnel lists in real time, in one place. Your Emergency Response Plan will never be out of date again.

SMART Response will become an invaluable tool and you will wonder how you ever got along without it.

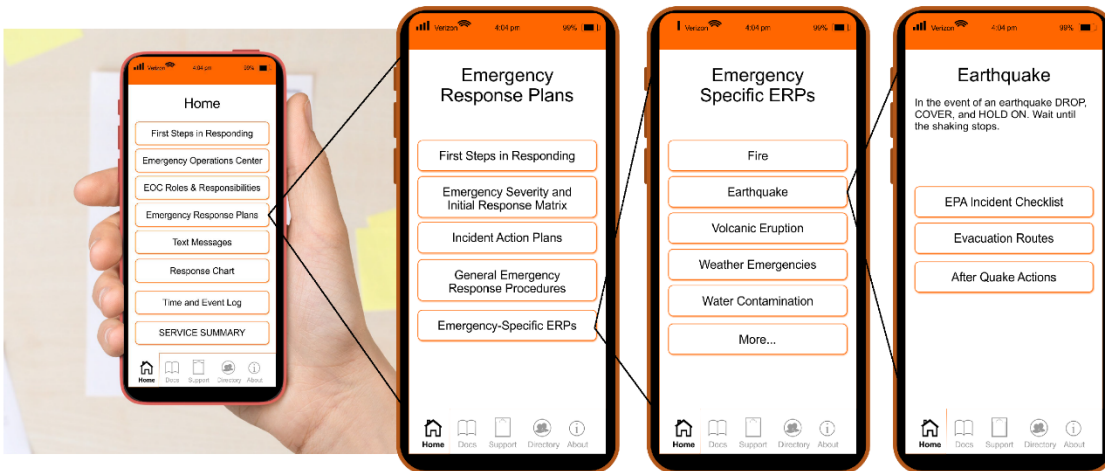

SMART RESPONSE APP – HOME SCREEN SAMPLE



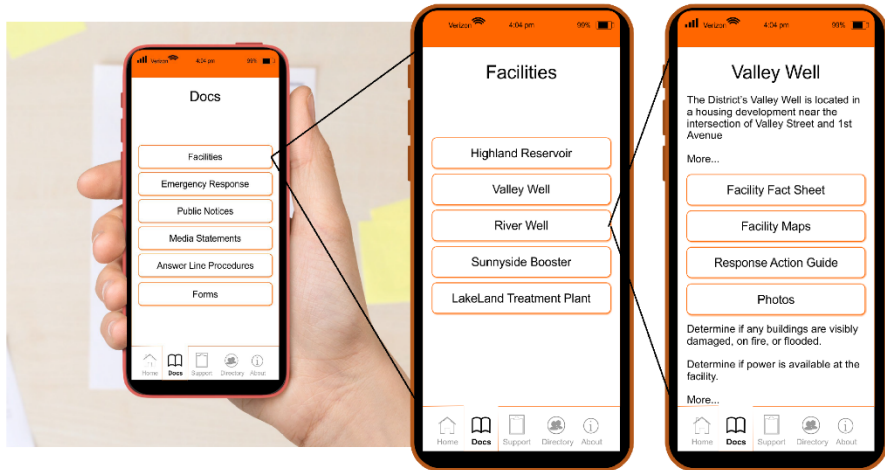

SMART RESPONSE APP – DOCUMENT SAMPLE

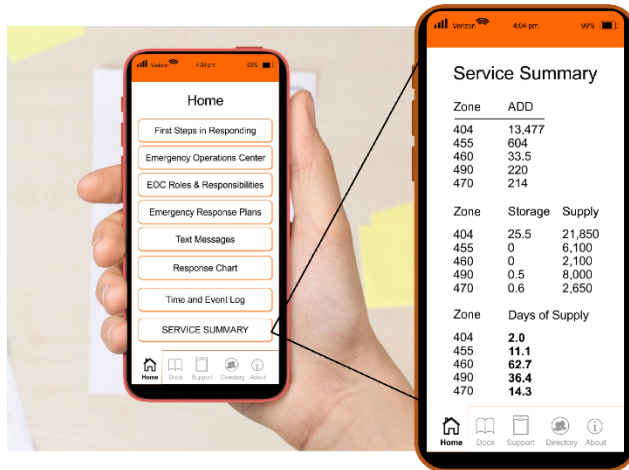

SMART RESPONSE APP – SYSTEM DASHBOARD SAMPLE

